



**CLADE**  
**OAK 300kW HEAT PUMP //**

March 2023 //



## THE CLADE OAK 300kW //

Single unit combining; compressor station, controls, gas cooler and water side pump, evaporator section

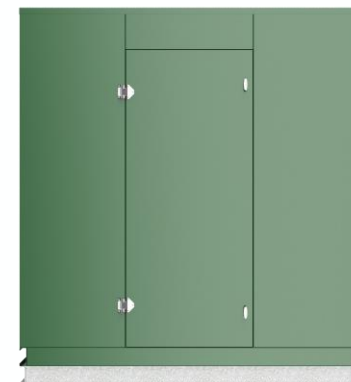
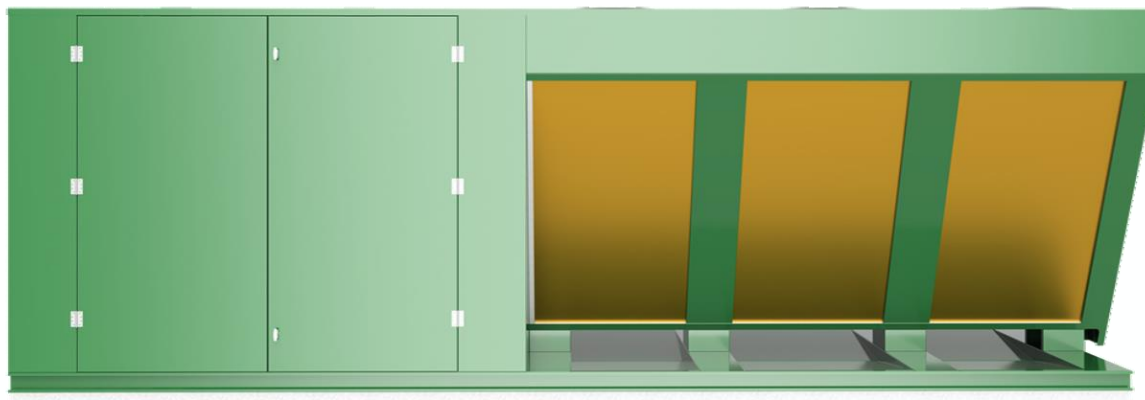



# DIMENSIONAL INFORMATION //

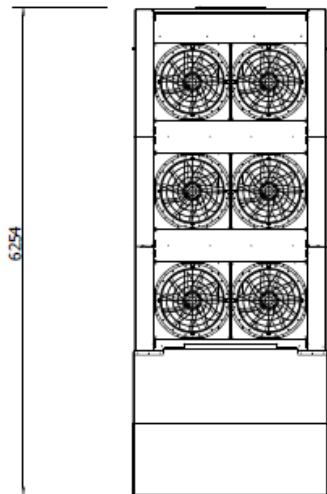

APPROX WEIGHT = 5351Kg

DIMENSIONED OUTSIDE (mm) UNLESS STATED

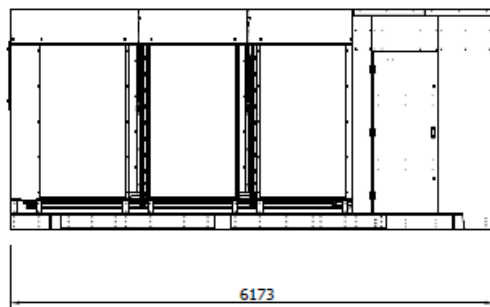
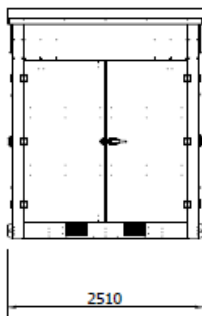
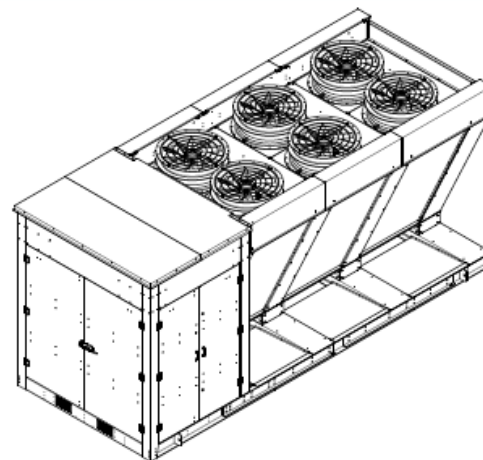



## TECHNICAL INFORMATION //

Clade Oak 300kW ASHP - v1.1		
Nominal conditions: Water side		flow 45c to 85c Return temperature <35°C
Nominal conditions: CO <sub>2</sub> side		Ambient air temperature +3°C (85% RH) and -9°C evaporation
Compressor Manufacturer		Dorin
Compressor Heating Qty	Pcs.	2
Compressor Paralell Qty	Pcs.	1
Compressor Power @ Design total	kW	119.9
Evaporator fans Power at design	kW	13
Total	kW	135
Total Amps	A	232.5
Variable speed drive (VSD)	Pcs.	2
Refrigerant charge (CO <sub>2</sub> )	kg	265
Electrical supply	-	3~ 400V 50 HZ
Unit Weight (empty)	kg	5,351
Unit Weight (operational)	kg	5,629
Water Volume	L	13
Sound Power	dB(A)	88
Sound Pressure 1m	dB(A)	66
Sound Pressure 10m	dB(A)	55
Connections waterside flow		54mm Copper
Connections waterside Return		54mm Copper
Connections waterside Pressure Rating	PN	6
Waterside Burst Disk	PN	6
Waterside Flow/Return Temp	C	65/30
Communication protocol	-	MODBUS/BACNET
IP-Class	-	IP54
Evaporators Type		V Block
No. evaporators	Pcs.	6
Fin Material	-	AL/MG
Defrost Type	-	Cool Gas CO <sub>2</sub>
Defrost medium	-	CO <sub>2</sub>
Defrost design/condition	-	> +6c ambient Off Cycle / < +6c ambient Cool Gas
Fan regulation	-	0-10v
Colour	-	BS4800 00A05 Goosewing Grey Textured paint







# HEAT PUMP PERFORMANCE //

Clade Heat Pump Performance Characteristics																													
Model name	Nameplate output (kW)	Output Temp (°C)	Return Temp (°C)	SCOP	SPF	-10°C External			-5°C External			0°C External			5°C External			10°C External			15°C External			20°C External			25°C External		
						QH (kW)	PI (kW)	COPH (-)	QH (kW)	PI (kW)	COPH (-)	QH (kW)	PI (kW)	COPH (-)	QH (kW)	PI (kW)	COPH (-)	QH (kW)	PI (kW)	COPH (-)	QH (kW)	PI (kW)	COPH (-)	QH (kW)	PI (kW)	COPH (-)	QH (kW)	PI (kW)	COPH (-)
Oak 300kW	300	55	35	2.8	2.9	240	117	2.06	300	131	2.29	330	128	2.57	360	126	2.86	360	115	3.13	360	106	3.39	360	99	3.63	360	91	3.95
		60	35	2.8	2.9	240	117	2.06	300	131	2.29	330	128	2.57	360	126	2.86	360	115	3.13	360	106	3.39	360	99	3.63	360	91	3.95
		65	35	2.8	2.9	240	117	2.06	300	131	2.29	330	128	2.57	360	126	2.86	360	115	3.13	360	106	3.39	360	99	3.63	360	91	3.95
		70	35	2.8	2.9	240	119	2.01	300	136	2.2	330	132	2.5	360	129	2.8	360	118	3.05	360	109	3.3	360	101	3.55	360	92	3.9
		75	35	2.8	2.9	240	120	2	300	136	2.2	330	132	2.5	360	129	2.8	360	118	3.05	360	109	3.3	360	101	3.55	360	92	3.9
		80	35	2.8	2.9	240	120	2	300	136	2.2	330	132	2.5	360	129	2.8	360	118	3.05	360	109	3.3	360	101	3.55	360	92	3.9

Clade Heat Pump Performance Characteristics																													
Model name	Nameplate output (kW)	Output Temp (°C)	Return Temp (°C)	SCOP	SPF	-10°C External			-5°C External			0°C External			5°C External			10°C External			15°C External			20°C External			25°C External		
						QH (kW)	PI (kW)	COPH (-)	QH (kW)	PI (kW)	COPH (-)	QH (kW)	PI (kW)	COPH (-)	QH (kW)	PI (kW)	COPH (-)	QH (kW)	PI (kW)	COPH (-)	QH (kW)	PI (kW)	COPH (-)	QH (kW)	PI (kW)	COPH (-)	QH (kW)	PI (kW)	COPH (-)
Oak 300kW	300	55	30	3	3.1	240	108	2.22	300	121	2.48	330	119	2.78	360	117	3.09	360	106	3.39	360	98	3.66	360	92	3.93	360	84	4.27
		60	30	3	3.1	240	108	2.22	300	121	2.48	330	119	2.78	360	117	3.09	360	106	3.39	360	98	3.66	360	92	3.93	360	84	4.27
		65	30	3	3.1	240	108	2.22	300	121	2.48	330	119	2.78	360	117	3.09	360	106	3.39	360	98	3.66	360	92	3.93	360	84	4.27
		70	30	3	3.1	240	112	2.15	300	125	2.4	330	122	2.7	360	120	3	360	109	3.3	360	100	3.6	360	94	3.85	360	86	4.2
		75	30	3	3.1	240	112	2.15	300	125	2.4	330	122	2.7	360	120	3	360	109	3.3	360	100	3.6	360	94	3.85	360	86	4.2
		80	30	3	3.1	240	112	2.15	300	125	2.4	330	122	2.7	360	120	3	360	109	3.3	360	100	3.6	360	94	3.85	360	86	4.2



## BUILDING CONNECTIONS //

### POWER

3 phase.

Connection box mounted in position shown.

Isolation at control panel only.

Installer to provide local isolator external to heat pump.

### HEATING

Supplied with primary pump with 14m spare head.

Flow and return located in position shown.

### CONDENSATE

Condensate from the evaporator will drain centrally from the base of the unit.

It is recommended that a gully be installed below the heat pump and lead to a soak away.

### CONTROLS

The heat pump has self contained controls that manage its operation and the primary pump.

#### Alarms

- Hardwired shut down signal for fire alarm
- CO<sub>2</sub> detection
- Other fault
- High return water temperature.

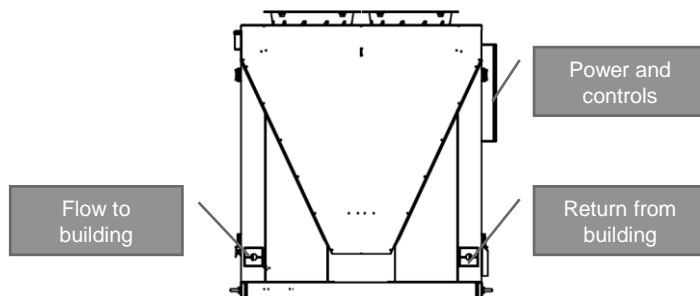



# LEEDS MANUFACTURING CENTRE //



- UK based
- 35 years of engineering experience
- Leeds manufacturing division
- Committed to sustainable business and sustainable products
- Investing in people, diversity & inclusion
- Non leveraged, owner operated

**ISO**  
 ACCREDITATIONS  
 ISO 9001:2015  
 ISO 14001:2015  
 OHSAS ISO 18001:2007

**HEALTH & SAFETY**  
 CERTIFICATIONS  
 Altus Assured Vendor Award  
 Altus CDM Vendor Award  
 CHAS  
 Sales Contractor



THANK YOU //

[www.clade-es.com](http://www.clade-es.com)

[Sales@clade-es.com](mailto:Sales@clade-es.com)

[Aftersales@clade-es.com](mailto:Aftersales@clade-es.com)

Head Office & Registered Office //  
Bristol & Bath Science Park,  
Dirac Crescent, Emersons Green,  
BRISTOL BS16 7FR

The Technology Centre //  
Unit R3 Gildersome Spur Industrial Estate,  
Stone Pits Lane, Morley,  
LEEDS LS27 7JZ

